

Technical Data Sheet

ISOBLOW STANDARD

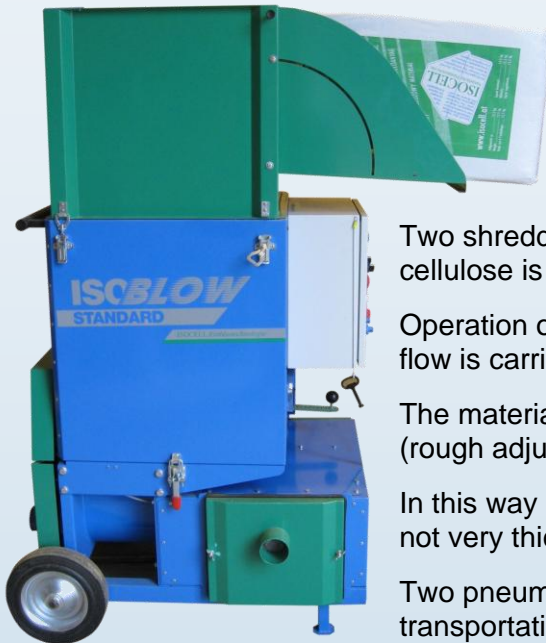

ISOblow Standard is a very high-performance blowing machine for installation of cellulose insulation as well as other approved loose and free-flow insulation.

Filling takes place through the filler hatch. The hopper can be removed for transportation.

Two shredder shafts in the lower part of the hopper ensure that the cellulose is adequately fluffed.

Operation of the **ISOblow Standard** as well as control of material and air flow is carried out via the ISOCELL radio control.

The material flow is controlled in two ways: with a slider via the airlock (rough adjustment) and by radio control that adjusts the airlock speed.

In this way it is possible to achieve a regular flow even if the insulation is not very thick.

Two pneumatic wheels and optimum weight distribution permit easy transportation (only one person is needed!).

All advantages at a glance:

- ✓ large hopper with two shredder shafts
- ✓ easy filling through filler hatch
- ✓ removable hopper
- ✓ 6-chamber airlock with abrasion-resistant rubber seals. No pressure drop – minimum wear
- ✓ flap valves protect blower from backflow
- ✓ easy operation via radio control
- ✓ double control of material flow: via airlock slider and via radio control
- ✓ frequency converter enables easy regulation of material and air flow
- ✓ airlock ventilation
- ✓ large pneumatic wheels permit easy transportation
- ✓ 380 V heavy current – constant high performance
- ✓ vacuum suction possible in combination with ISOCELL suction bin
- ✓ for increasing the air power, an additional blower station can be connected

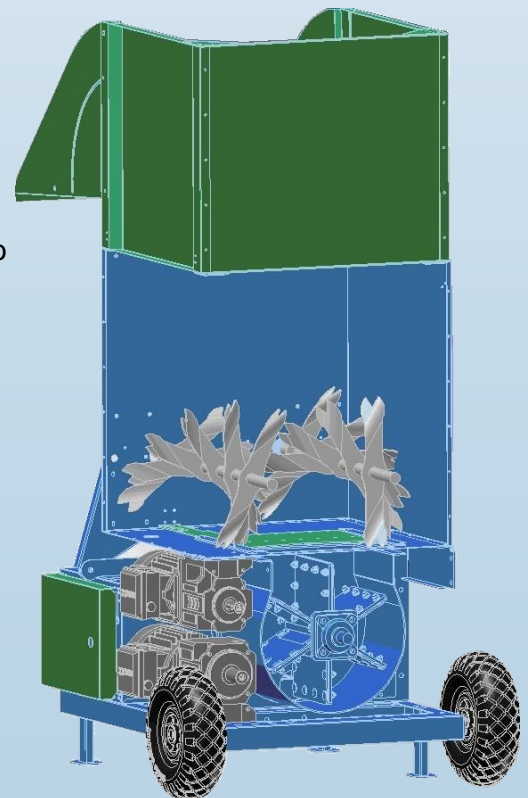

Technical Data Sheet

ISOBLOW STANDARD

Dimensions:	
Width:	800 mm
Length:	950 mm
Height:	1650 mm
Height without hopper:	1150 mm
Hopper capacity:	
	250 l = 2 sacks fluffed cellulose
Weight:	
	235 kg
Electrical connection:	
	380 V / 50 Hz, 16A
Operating energy input:	
Airlock drive	1.1 kW
Shredder drive:	0.75 kW
Air generation	3.4 kW
Total consumption	5.25 kW
Pressure data:	
Max. pressure	350 mbar
Max. air volume	390 m ³ /h
Fluffing:	
	2 shredder shafts
Standard operation:	
ISOCELL radio control (not included in price of machine)	Machine can be switched on and off. Air and material flow controlled via radio control
50 m control cord for remote control	To bridge any radio disturbances
50 m extension cable for base station	For greater range of transmission of radio control.
Output: <i>(the figures apply for ISOCELL cellulose insulation)</i>	
Loose blow:	approx. 50 – 60 sacks / hour
Dense blow:	approx. 35 – 40 sacks / hour
Roof:	up to 40 cm thick insulation possible
Wand:	up to 40 cm thick insulation

ISOCELL VertriebsgmbH ♦ Bahnhofstrasse 36 ♦ A-5202 Neumarkt am Wallersee
Tel: 0043 6216 4108-0 ♦ Fax: 0043 6216 7979 ♦ office@isocell.at